

Satellite L25 Series Detailed Product Specification¹

Model Name	Description	Part Number	UPC
L25-S119	Microsoft® Windows® XP Home Edition, Intel® Celeron® M Processor 370, 256MB DDR2, 60GB (5400 RPM) PATA, CD-RW/DVD-ROM, 15.0" TruBrite™ XGA, ATI RADEON® XPRESS 200M, TV-Out, 802.11 b/g, CD Buttons, 1-year Limited Warranty	PSL2XU-00J00D	032017415065

Operating System²

- Microsoft® Windows® XP Home Edition

Processor and Chipset³

- Intel Celeron® M Processor 370
 - 1.50GHz, 1MB L2, 400MHz FSB
- ATI RADEON® XPRESS 200M Chipset

Memory⁴

- Configured with 256MB DDR2 SDRAM (both memory slots may be occupied)
- 256MB(min)/2048MB (max), 2 memory slots using 256MB, 512MB, or 1024MB PC4200 DDR2 533MHz SDRAM 1.8V SODIMM memory modules, dual-channel support requires two memory modules of same capacity and clockspeed

Hard Disk Drive⁵

- 60GB (5400 RPM); Enhanced IDE (ATA-6) hard disk drive; 9.5mm height; user removable

Fixed Bay Optical Disk Drive

- CD-RW/DVD-ROM drive maximum speed and compatibility:
 - CD-ROM (24x:read), CD-R (24x:write), CD-RW (24x:write), DVD-ROM (8x:read)

Display⁶

- 15.0" diagonal TruBrite™ TFT active-matrix LCD display at 1024x768 native resolution (XGA)

Graphics⁷

- ATI RADEON® X200M 32MB-128MB dynamically allocated shared graphics memory.

Sound

- 16-bit stereo software sound
 - Supports 3D Sound, Direct 3D Sound, DirectSound, Direct Music, MIDI (playback)
- Sound Volume Control by keyboard
- Built-in stereo speakers

Input Devices

- Keyboard
 - 84 key US keyboard
 - Hot Key Functions (Fn)
 - Windows Key Function
 - Application Key Function
- TouchPad™ pointing device
- CD/DVD control buttons (Skip to Previous/Next Track, Play, Stop)

Communications

- Integrated V.92 software modem⁸
- 10/100 Base-TX Ethernet
- Atheros® 802.11b/g wireless-LAN⁹

Expandability

- 2 main memory slots. Both slots may be occupied.
- 1 PC Card slot support 1 Type II, PCMCIA R2.01, PC Card16, CardBus

Ports

- RGB (monitor) port
- TV-out (S-Video)
- 3 Universal Serial Bus (USB) ports (v2.0)
- External Microphone jack
- Headphone jack
- RJ-45 LAN port
- RJ-11 modem port

Physical Description for this Product Series

- Dimensions (WxDxH Front/H Rear): 13.1" (332 mm) x 10.6" (270mm) x 1.12" (28.5 mm)[F]/ 1.44" (36.6 mm)[R] without feet
- Weight: Starting at 5.88 lbs (2.67 kg) depending upon configuration¹⁰
- Indicators: Power, Hard Drive, CD/DVD-ROM, Caps Lock, Wireless Communication, Main Battery Charging Status, Sleep Suspend Mode
- Chassis Description
 - Case material: Polycarbonate ABS
 - LCD Cover Color: Black
- Physical Security
 - Slot for cable lock
 - Items protected by screws: Memory & Hard Disk
 - Items protected by sliding latch: Main Battery Pack
- Software Security
 - Passwords: User power-on password, supervisor password, set-up security
 - Hotkey locks: Screen Blank
 - Screen Saver (by software)

Power Supply

- 65W (19V 3.42A) Auto sensing external AC Adapter, 100-240V / 50-60Hz frequency (Universal) input.
- Dimensions (WxDxH): 4.25" (108.0mm) x 1.34" (34.0mm) x 1.85" (47.0mm)
- Weight: starting at 0.55 lbs (250 g)

Battery¹¹

- 4-cell (2000mAh) rechargeable, removable Lithium Ion (Li-Ion) battery pack
- Dimensions (WxDxH): 8.10" (205.8mm) x 0.78" (19.8mm) x 2.40" (60.9mm)
- Weight: starting at 0.62 lbs (281 g)
- Battery Life (measured by MobileMark™)¹²
 - Included 4-cell battery: 1 hour, 30 minutes
- Recharge Time
 - Main Battery Off/On – approximately 3 hrs/approximately 6 hrs

BIOS

- ACPI v1.0b, PNP v1.0a, VESA v2.0, DPMS, DDC, SM BIOS v2.31, PCI BIOS v2.2 support

Software¹³

- Toshiba Software and Utilities
 - TOSHIBA ConfigFree®
 - TOSHIBA Custom Utilities
 - Toshiba Notebook Maximizer
 - Electronic User's Guide
- Third-party Software
 - Microsoft Office® OneNote™ 2003
 - Microsoft Works™ Version 8.0
 - McAfee® VirusScan™ (30-day Trial)
 - Sun® Java™ 2 Runtime Environment
 - Adobe® Acrobat® Reader version 5.0
 - InterVideo® WinDVD® 5
 - InterVideo® WinDVD Creator 2 Platinum
 - Sonic Solutions® PrimeTime™
 - Sonic Solutions® RecordNow!™ Basic for Toshiba
 - Sonic Solutions® Drive Letter Access™ (DLA)
 - Microsoft® Windows Media Player version 10
 - AOL® Internet Service (90-day trial)¹⁴
 - AT&T® Worldnet® Service (30-day trial)¹⁵

Environmental Specifications

	Operating
Temperature ¹⁶	5° to 35° C (41° to 95° F)
Thermal Gradient	15° C per hour (max)
Relative Humidity (non-condensing)	20% to 80%
Altitude (relative to sea level)	0 to 3,000 meters
Shock	10G
Vibration	0.5G

Satellite – 1-year standard limited warranty¹⁷

Standard Limited Warranty Upgrades and Extensions

Toshiba offers many different standard limited warranty extensions and enhanced service plans such as SystemGuard®, At-Home Repair, and Service Express to provide additional support to your notebook PC. For a full description and complete list of programs and program extensions, please visit www.pcsupport.toshiba.com

Recommended Services

Limited Warranty Extensions

Extends the standard limited warranty for up to 3 years from the original notebook purchase date. See Toshiba Service Plan Agreement for program terms and conditions at www.pcsupport.toshiba.com

Part Number	Description
SWC-PEQQ2V	2nd Year Limited Warranty Extension
SWP-PEQQ3V	2nd/3rd Year Limited Warranty Extension

SystemGuard¹⁸ Advanced Protection Coverage w/ ServiceExpress

Provides advanced protection from damage caused by accidental drops, spills and even screen breakage. Select your express repair service with either Depot Express or Carry-In Express and go to the front of the line. Limited Warranty Extension included except with 1 Year plan.

Part Number	Description
SWC-PSGQ1V	1st Year
SWC-PEGQ2V	1st/2nd Year + Limited Warranty Extension
SWP-PEGQ3V	1st/2nd/3rd Year + Limited Warranty Extension

SystemGuard¹⁹ Advanced Protection Coverage + At-Home Repair

Subject to Change

While Toshiba has made every effort at the time of publication to ensure the accuracy of the information provided herein, product specifications, configurations, prices, system/component/options availability are all subject to change without notice. For the most up-to-date product information about your computer, or to stay current with the various computer software or hardware options, visit Toshiba's Web site at <http://www.pcsupport.toshiba.com>

Combines SystemGuard and At-Home Repair coverage. Limited Warranty Extension included except with 1 Year plan.

Part Number	Description
SWC-PSGH1V	1st Year
SWC-PEGH2V	1st/2nd Year + Limited Warranty Extension
SWP-PEGH3V	1st/2nd/3rd Year + Limited Warranty Extension

ServiceExpress

Select your express repair service with either Depot Express or Carry-In Express. Depot Express: Toshiba will make reasonable efforts to complete repair of your notebook and return the notebook to you by the next business day via overnight shipment (excluding weekends and holidays). Instructions and box will be provided to you for packing and shipping the notebook to Toshiba. Carry-In Express: A Premier ASP will make reasonable efforts to complete repair of your notebook by the next business day (excluding weekends and holidays). Limited Warranty Extension included except with 1 Year plan. See Toshiba Service Plan Agreement for program terms and conditions at

www.pcsupport.toshiba.com

Part Number	Description
SWC-PSQP1V	1st Year
SWC-PEQP2V	1st/2nd Year + Limited Warranty Extension
SWP-PEQP3V	1st/2nd/3rd Year + Limited Warranty Extension

At-Home Repair

Toshiba will make reasonable efforts to provide on-site service at customer's home location by the second business day (excluding weekends and holidays) to perform the necessary hardware repairs. Limited Warranty Extension included except with 1 Year plan. See Toshiba Service Plan Agreement for program terms and conditions at

www.pcsupport.toshiba.com

Part Number	Description
SWC-PSQH1V	1st Year
SWC-PEQH2V	1st/2nd Year + Limited Warranty Extension
SWP-PEQH3V	1st/2nd/3rd Year + Limited Warranty Extension

Accessories

For additional and most updated accessories, please visit www.accessories.toshiba.com

Memory

Part Number	Description
KT533D2/256	Kingston DDR2 533, 256MB
KT533D2/512	Kingston DDR2 533, 512MB
KT533D2/1G	Kingston DDR2 533, 1GB

Power

Part Number	Description
PA3396U-1ACA	Toshiba 65W Global AC Adapter
PA3420U-1BRS	Toshiba Primary Li-Ion Battery Pack (8 cell)

Security & Protection

Part Number	Description
NWDEFCL	Targus-Noteworthy DEFCON CL Cable Lock

Storage

Part Number	Description
PA3109U-1FDD	Toshiba USB Floppy Disk Drive Kit

Bluetooth/Wireless

Part Number	Description
NWDEFCL	Toshiba USB Adaptor with Bluetooth™ 2.0+EDR Capability

Return Policy

Notwithstanding anything to the contrary in any third party License Agreement or product documentation supplied with your PC, Toshiba America Information Systems, Inc. ("TAIS") does not accept the return of component parts, or bundled software, that have been removed from the PC system. Pro-rata refunds on individual PC components or bundled software, including the operating system, will not be granted. If you wish to return a complete PC system, contact the TAIS dealer where you purchased the product, and comply with the dealer's standard return policies and procedures.

Toshiba America Information Systems, Incorporated ("TAIS")
9740 Irvine Boulevard
Irvine CA 92618
ToshibaDirect website: <http://www.toshibadirect.com>
TAIS website for resellers: <http://sell.toshiba.com>
TAIS PC Support website: <http://pcsupport.toshiba.com>

Portégé, Satellite, Tecra, SelectBay, ConfigFree and SystemGuard are registered trademarks and Qosmio and EasyGuard are trademarks of Toshiba America Information Systems, Inc. and/or Toshiba Corporation. Intel, Celeron, Centrino, Intel Inside, Pentium, the Intel Centrino logo, and the Intel Inside logo are trademarks or registered trademarks of Intel Corporation or its subsidiaries in the United States and other countries. Microsoft and Windows are registered trademarks and OneNote registered is a trademark of Microsoft Corporation in the United States and/or other countries. Winstone® is a registered trademark and BatteryMark™ is a trademark of Ziff Davis Publishing Holdings Inc. in the U.S. and other countries. MobileMark™ is a trademark of the Business Applications Performance Corporation. Wi-Fi is a registered certification mark of the Wi-Fi Alliance. The Bluetooth word mark and logos are owned by the Bluetooth SIG, Inc. and any use of such marks by Toshiba is under license. NVIDIA and GeForce are registered trademarks or trademarks of NVIDIA Corporation in the United States and/or other countries. All other trademarks are the property of their respective owners.

¹ **Product Series Legal Footnote.** The product specifications and configuration information are designed for a product Series. Your particular model may not have all the features and specifications listed or illustrated. For more detailed information about the features and specifications on your particular model, please visit Toshiba's Web site at pcsupport.toshiba.com.

Product Offering Legal Footnote. Toshiba America Information Systems, Inc. reserves the right to modify or withdraw this offer at anytime without notice.

² **Operating System.** Certain Microsoft® software product(s) included with this computer may use technological measures for copy protection. IN SUCH EVENT, YOU WILL NOT BE ABLE TO USE THE PRODUCT IF YOU DO NOT FULLY COMPLY WITH THE PRODUCT ACTIVATION PROCEDURES. Product activation procedures and Microsoft's privacy policy will be detailed during initial launch of the product, or upon certain reinstallations of the software product(s) or reconfigurations of the computer, and may be completed by Internet or telephone (toll charges may apply).

Some software may differ from its retail version (if available), and may not include user manuals or all program functionality.

³ **Processor (Central Processing Unit).**

CPU performance in your computer product may vary from specifications under the following conditions:

1. use of certain external peripheral products
2. use of battery power instead of AC power
3. use of certain multimedia, computer generated graphics or video applications
4. use of standard telephone lines or low speed network connections
5. use of complex modeling software, such as high end computer aided design applications
6. use of several applications or functionalities simultaneously
7. use of computer in areas with low air pressure (high altitude >1,000 meters or >3,280 feet above sea level)
8. use of computer at temperatures outside the range of 5°C to 35°C (41°F to 95°F) or >25°C (77°F) at high altitude (all temperature references are approximate and may vary depending on the specific computer model – please visit the Toshiba website at www.pcsupport.toshiba.com for details).

CPU performance may also vary from specifications due to design configuration.

Under some conditions, your computer product may automatically shut-down. This is a normal protective feature designed to reduce the risk of lost data or damage to the product when used outside recommended conditions. To avoid risk of lost data, always make back-up copies of data by periodically storing it on an external storage medium. Use your computer product only under recommended conditions. Read additional restrictions under "Environmental Conditions" in your product "Detailed Specs." Contact Toshiba Technical Service and Support for more information.

⁴ **Memory (Main System).** Part of the main system memory may be used by the graphics system for graphics performance and therefore reduce the amount of main system memory available for other computing activities. The amount of main system memory allocated to support graphics may vary depending on the graphics system, applications utilized, system memory size and other factors.

⁵ **Hard Disk Drive (HDD) Capacity.**

1 Gigabyte (GB) means 1000 x 1000 x 1000 = 1,000,000,000 bytes using powers of 10. The computer operating system, however, reports storage capacity using powers of 2 for the definition of 1 GB = 1024 x 1024 x 1024 = 1,073,741,824 bytes, and therefore may show less storage capacity. Available storage capacity will also be less if the product includes one or more pre-installed operating systems, such as Microsoft Operating System and/or pre-installed software applications, or media content. Actual formatted capacity may vary.

⁶ **Display.** Small bright dots may appear on your screen display when you turn on your PC. Your display contains an extremely large number of thin-film transistors (TFT) and is manufactured using high-precision technology. Any small bright dots that may appear on your display are an intrinsic characteristic of the TFT manufacturing technology. Over a period of time, and depending on the usage of the computer, the brightness of the screen will deteriorate. This is also an intrinsic characteristic of the screen technology.

When the computer is operated on battery power, the screen will dim and you may not be able to increase the brightness of the screen while on battery power.

⁷ **Graphics (Graphics Processing Unit).**

GPU performance may vary depending on product model, design configuration, applications, power management settings and features utilized. GPU performance is only optimized when operating in AC power mode and may decrease considerably when operating in battery power mode.

⁸ **Modem Speed.** Due to FCC limitations, speeds of 53 kbps are the maximum permissible transmission rates during download. Actual data transmission speeds will vary depending on line conditions.

⁹ **Wireless.** Wireless connectivity and some features may require you to purchase additional software, external hardware or services. Availability of public wireless LAN access points may be limited. The transmission speed over the wireless LAN and the distance over which wireless LAN can reach may vary depending on surrounding electromagnetic environment, obstacles, access point design and configuration, and client design and software/hardware configurations. The actual transmission speed will be lower than the theoretical maximum speed. To use the Atheros SuperAG™ or SuperG™ wireless function, if available, your client and access point must support the corresponding feature. Performance of these functions may vary depending on the format of data transmitted.

¹⁰ **Weight.** Weight may vary depending on product configuration, vendor components, manufacturing variability and options selected.

¹¹ **Battery Life.** Battery life may vary considerably from specifications depending on product model, configuration, applications, power management settings and features utilized, as well as the natural performance variations produced by the design of individual components. Published battery life numbers are achieved on select models and configurations tested by Toshiba at the time of publication. See "Detailed Specs" for specific battery measurement test. Recharge time varies depending on usage. Battery may not charge while computer is consuming full power. After a period of time, the battery will lose its ability to perform at maximum capacity and will need to be replaced. This is normal for all batteries. To purchase a new battery pack, see the accessories information that shipped with your computer or visit the Toshiba web site at www.accessories.toshiba.com.

¹² **Battery Life - MobileMark™.** Measured by MobileMark. MobileMark is a trademark of the Business Applications Performance Corporation.

¹³ **Software.** Some software may differ from its retail version (if available), and may not include user manuals or all program functionality.

Certain Microsoft® software product(s) included with this computer may use technological measures for copy protection. IN SUCH EVENT, YOU WILL NOT BE ABLE TO USE THE PRODUCT IF YOU DO NOT FULLY COMPLY WITH THE PRODUCT ACTIVATION PROCEDURES. Product activation procedures and Microsoft's privacy policy will be detailed during initial launch of the product, or upon certain reinstallations of the software product(s) or reconfigurations of the computer, and may be completed by Internet or telephone (toll charges may apply).

¹⁴ **AOL® Internet Service.** Availability may be limited, especially during peak times. TO AVOID BEING CHARGED A MONTHLY MEMBERSHIP FEE, SIMPLY CANCEL BEFORE THE THREE-MONTH PROMOTIONAL PERIOD ENDS. Premium services carry surcharges and communication surcharges may apply, including AK, even during promotional period. Members may incur telephone charges on their phone bill, depending on their location and calling plan, even during promotional period. Available to new AOL members in the United States, age 18 or older; a major credit card or checking account is required.

¹⁵ **AT&T® Worldnet® Service.** Telephone access and other charges and other terms and conditions may apply. Offer available to new customers only.

¹⁶ **Temperature (Environmental) Conditions.** All temperature references are approximate and the performance of your computer may vary from specifications even when operating within the recommended temperature range.

¹⁷ **Warranty.** Toshiba's standard limited warranty, extended warranty and service upgrade terms and conditions are available at www.warranty.toshiba.com.

¹⁸ SystemGuard coverage must be purchased within the first 30 days of purchase. See Toshiba Service Plan Agreement for program terms and conditions at www.pcsupport.toshiba.com

¹⁹ **SystemGuard:** SystemGuard coverage must be purchased within the first 30 days of purchase. See Toshiba Service Plan Agreement for program terms and conditions at www.pcsupport.toshiba.com

Front with display open

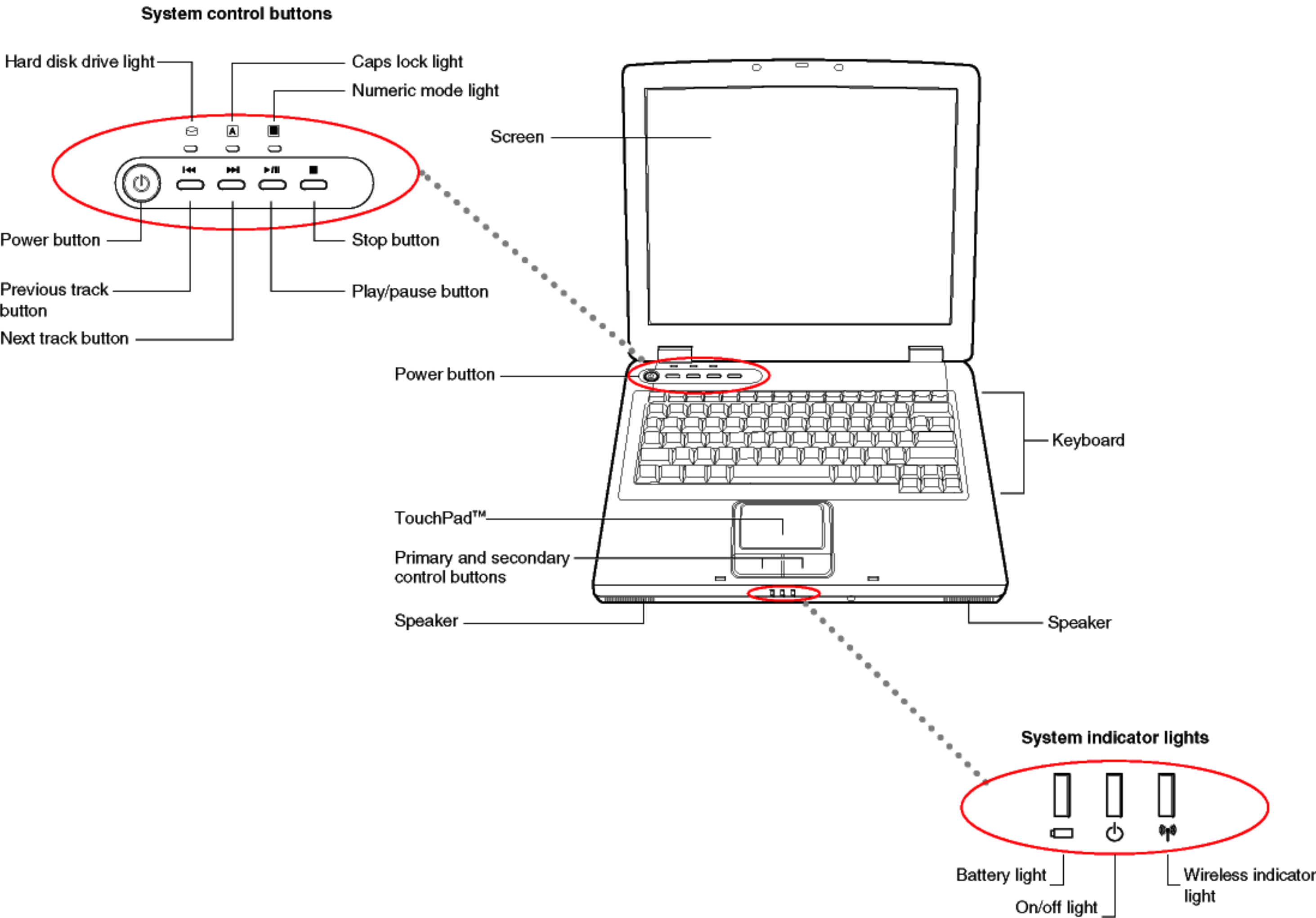

Front with display closed

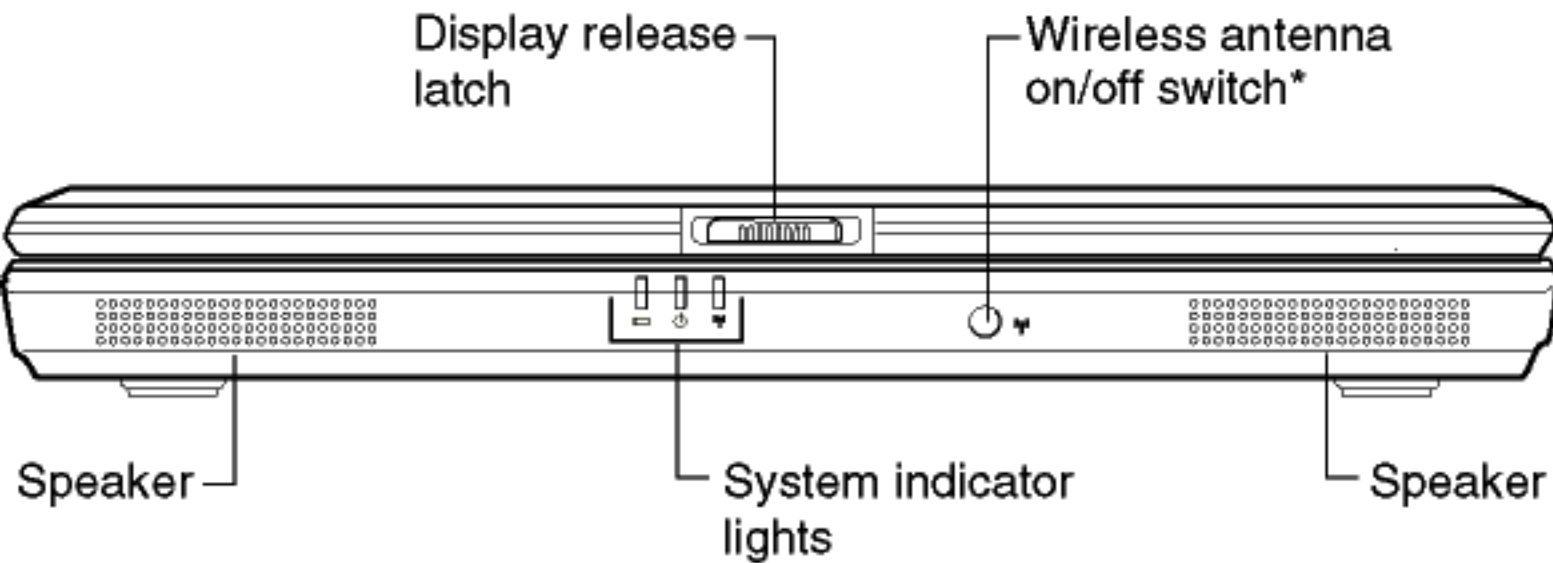

*Available on certain models.

Left side

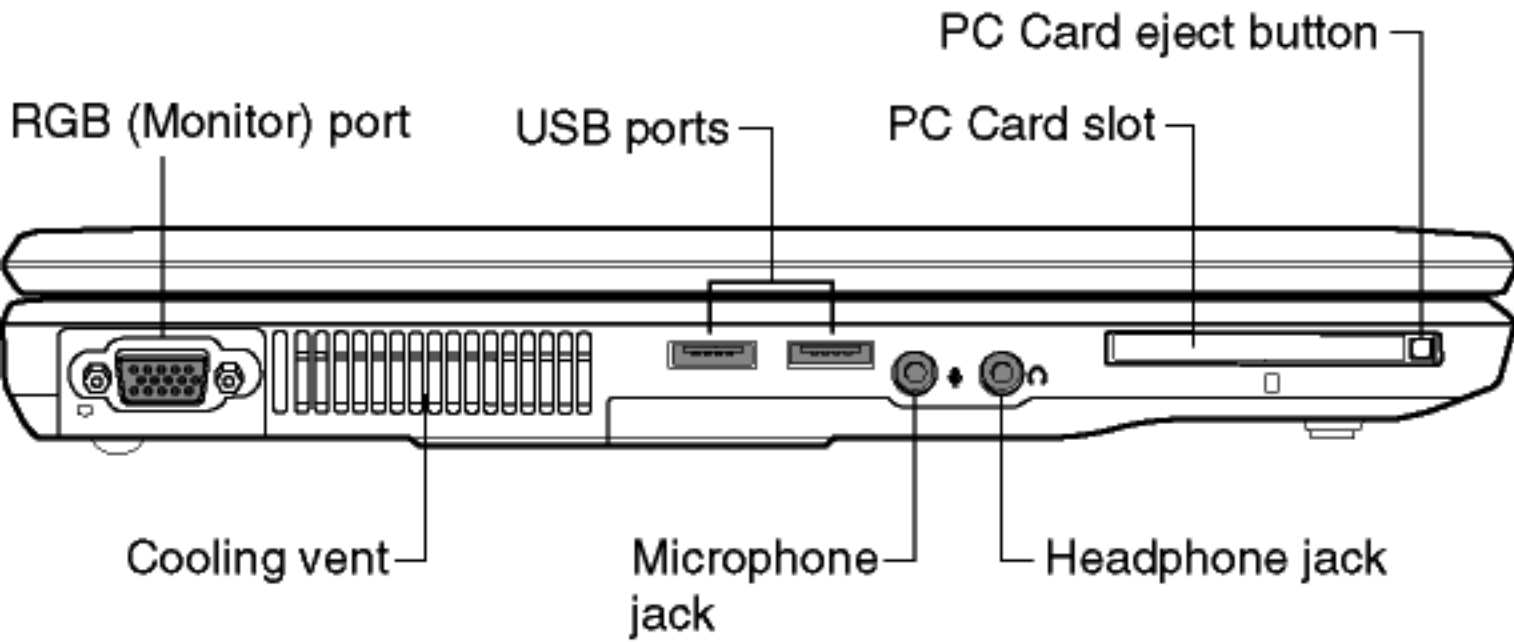

Right side

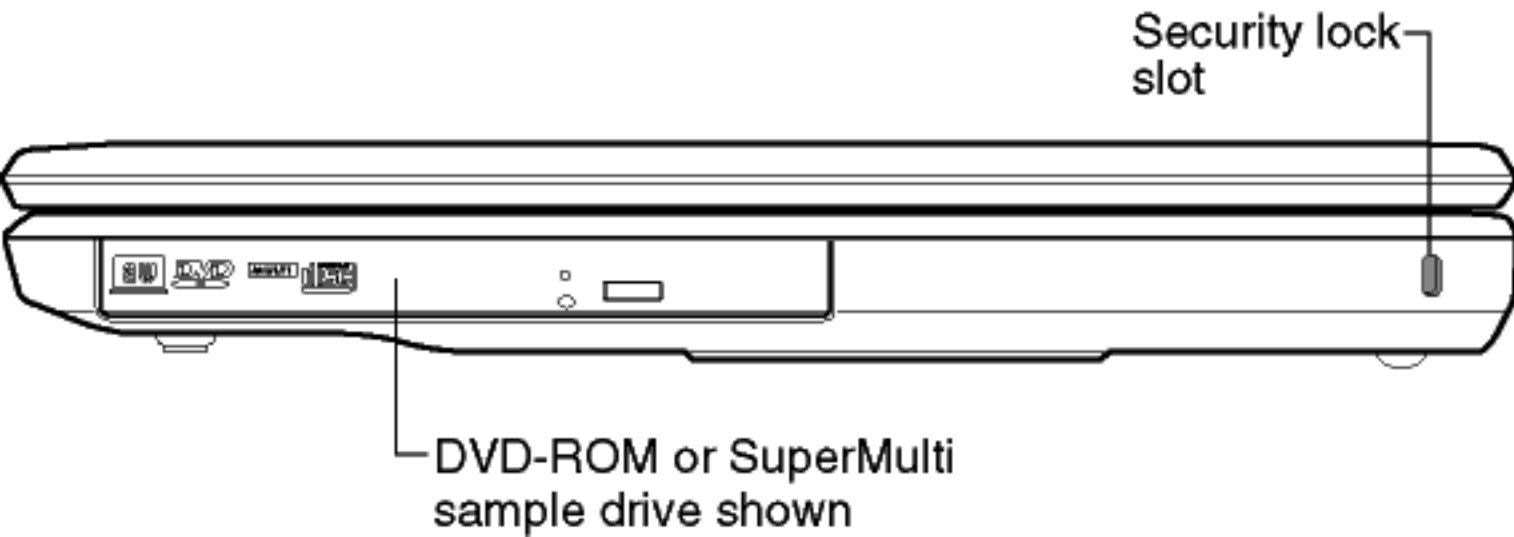

Back

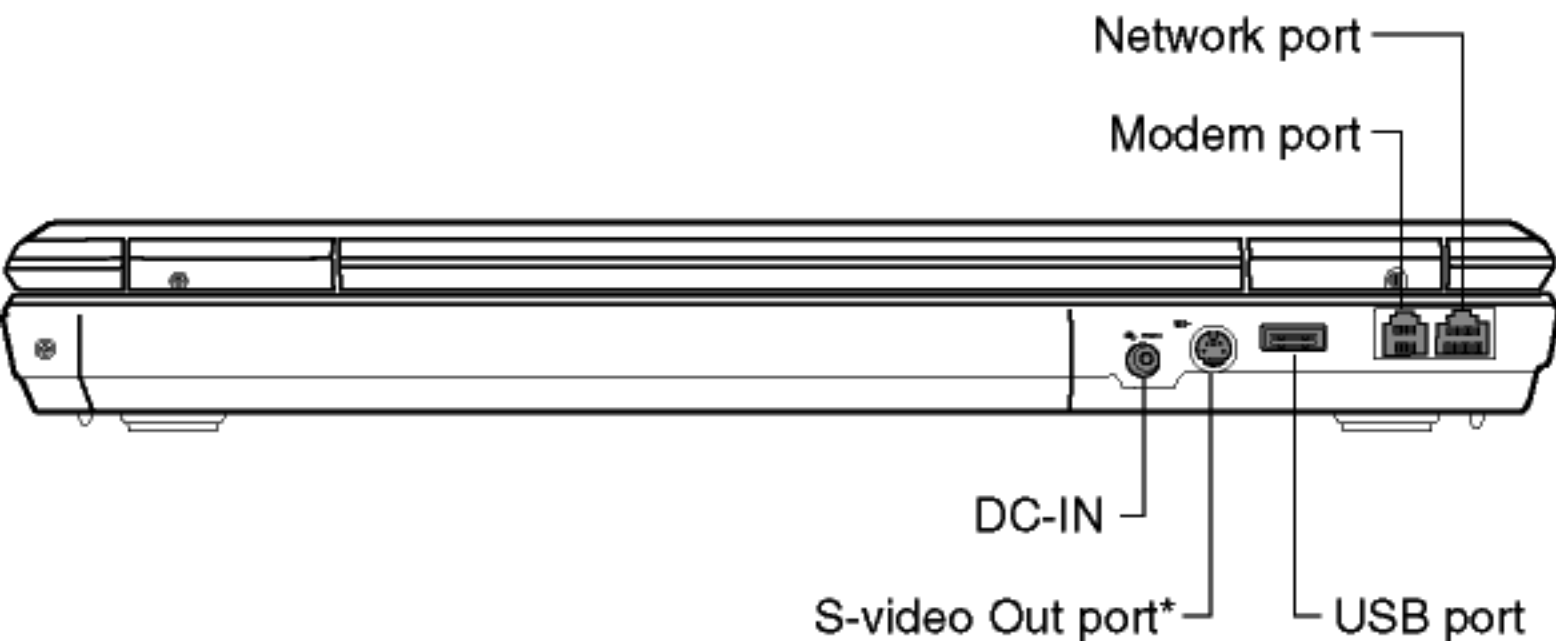

*Available on certain models.

Underside

